



A Family Reunion: *Hversu Noregr byggðist* and the first chapter of the *Flateyjarbók Ættartölur* as a textual unity

By Ben Allport

Opprinnelseslegenden *Frá Fornjóti ok hans attmönnum* ‘Om Fornjot og slektningene hans’ er bevart i to versjoner i *Flateyjarbók*, et kjent islandsk samlehandskrift fra trettenhundretallet. Legendene følger opprinnelsen til forskjellige norske og orknøyske dynastier tilbake til to brødre som heter Nórr og Górr. Den antatt yngste versjonen, «Nórrversjonen», er representert av en tekst som heter *Hversu Noregr byggðist* ‘Hvordan Norge ble bygd’. Teksten står i et komplekst forhold til de fem kapitlene med *Ættartölur* ‘Slektsforskning’ som følger den i manuskriptet. Selv om innhold og tema ligner i alle disse tekstene, er de tydelig avgrenset av initialer som ble satt inn av skriveren Magnús Þórhallsson. Magnús har ofte blitt tillagt en viktig rolle i sammenheng med disse kapitlene. Denne artikkelen utforsker forholdet mellom *Hversu Noregr byggðist* og det første av slektsforskningskapitlene. Det demonstreres hvordan fortelling og temaer er gjennomgående i begge tekstene og at begge tekstene bruker de samme kildene til å identifisere Nórrs etterkommere som fremstående personer. På dette grunnlaget blir det argumentert for å betrakte de to tekstene som en tekstlig enhet, delt i to da manuskriptet ble samlet. Den narrative strukturen til begge tekstene kan sammenlignes med legendens andre versjon, *Fundinn Noregr* ‘Norge grunnlagt’. Artikkelen viser at en tilsvarende sammenheng som mellom *Hversu Noregr byggðist* og det første slektsforskningskapittelet, ikke fins mellom disse to tekstene og de siste fire slektsforskningskapitlene. Derfor blir det foreslått at Magnús Þórhallsson neppe er forfatteren av Nórrversjonen slik vi kjenner den.

1 Introduction*

The student of medieval history is frequently forced to confront an underlying tension between treating literary sources as independent entities and regarding them as a part of the manuscript context that preserves them. We must regularly reconcile the incarnate form of surviving texts with the rich history of transmission they are known or suspected to have enjoyed, and ponder the changes wrought upon them by the codification process. This article considers the largely unexplored relationship between several texts found in the late-fourteenth-century manuscript known as *Flateyjarbók* (Reykjavík, Árni Magnússon Institute, GkS 1005 fol.), perhaps the most famous compilation of saga material and assorted miscellanea to have survived from medieval Iceland.

Among the expansive contents of *Flateyjarbók* are two substantially different variants of a single origin legend – sometimes referred to collectively as *Frá Fornjóti ok hans attmönnum* ‘Concerning Fornjótr and his Kinsmen’ – the narrative details of which are otherwise unattested. The legend depicts the life of the mythical Nórr, the eponymous founder of the Norwegian kingdom, and his brother Górr, relating their offspring to various historical dynasties whose representatives were among the most significant characters in the narrative of Scandinavian history developed by Norse historiographers in the twelfth and thirteenth centuries. Most of the scholarly attention this legend has attracted has been lavished upon the variant considered to be the older of the two, *Fundinn Noregr* ‘Norway Founded’ (hereafter *FN*). *FN* forms the preface to *Orkneyinga saga*, which was first composed in the late twelfth century and updated in the 1220s (*Orkneyinga saga* 1965: x–xi; Clunies Ross 1983: 55; Finnbogi Guðmundsson 1993, 206 and 210; Rowe 2000: 443; 2005: 317; Beuermann 2011: 110–11). It derives the line of the jarls of Orkney from Górr, and the tradition it represents might therefore be regarded as the “Górr variant” of the legend.

* This research was made possible with the generous financial support of the Leverhulme Trust. My thanks go particularly to Dr Synnøve Midtbø Myking and Dr Tom Grant for their insightful feedback and suggestions during the writing and revision of this article. I am also indebted to Dr Elizabeth Ashman Rowe and Dr Jens Eike Schnall for their thoughts on earlier versions of the article, as well as to my anonymous reviewers for their suggested improvements.

The second variant existed in some form by c. 1290, when it lent its structure and several of its dynasts to the mythical preface of *Þorsteins saga Víkingssonar* (Rowe 2004: 135; 2005: 317). The variant elaborates at much greater length upon the offspring of Nórr and may thus be referred to as the “Nórr variant”. This variant and its history have received far less attention from scholars than the Górr variant and as such its history is less well understood. Allusions to the variant in secondary literature typically refer solely to the text known as *Hversu Noregr byggðist* ‘How Norway was Settled’, henceforth *HNB*. This text, which is far more genealogical in its structure than *FN*, is followed by five chapters of *Ættartölur* (Genealogies; henceforth *ÆI–5*) of Haraldr hárfagri ‘Fairhair’. *HNB* and *ÆI–5* were added to the manuscript during its second phase of production from 1388 by the scribe Magnús Þórhallsson, who has been attributed a significant role in compiling and shaping the genealogical data found in all of these texts.¹

HNB and the first of these genealogical chapters (*ÆI*) have a complex relationship. On the one hand, they share various dynasts and themes, but on the other, they are clearly demarcated in the manuscript, suggesting that Magnús regarded them as separate texts.² This prompts the following questions: how representative is *Flateyjarbók*’s demarcation between *HNB* and *ÆI* of the narrative and thematic relationship between the texts? What can these relationships tell us about the history of the texts prior to their appearance in *Flateyjarbók*?

In addressing these questions, this article demonstrates the extensive similarity in the themes, style, and sources which shaped the two texts. It explores the possibility that *HNB* and *ÆI* represent a single text

1. This was the conclusion reached by Sigurður Nordal (for which see Rowe 2005: 317–18 and 330) and has since gone essentially unchallenged.
2. Various editors have taken different approaches to the division of these texts. The 1860 edition of *Flateyjarbók* regards *HNB* and *ÆI–5* as two separate texts (*Hversu Noregr byggðiz*: 21–4; *Ættartölur*: 24–29), whereas the *Fornaldar sögur norðurlanda* series (*Hversu Noregr byggðist*: 75–87) groups all of these chapters under the title of *HNB*. In both editions, the three chapters of genealogical and regnal material that follow *ÆI–5* are grouped with them (*Ættartölur*: 28–29; *Hversu Noregr byggðist*: 86–87). These comprise a genealogy from Haraldr hárfagri to Óláfr Hákonarson – the king of Norway at the time of the first production phase of *Flateyjarbók* (Rowe 2005: 22–23) – a list of Norwegian kings, and a notice of Óláfr Hákonarson’s death. Although in some ways a continuation of *ÆI–5*, these chapters do not share the same sources or intent (i.e. of relating the descent of Haraldr hárfagri from legendary ancestors) and are thus not relevant to the present discussion.

(*HNB:Æ1*) which existed prior to its codification in *Flateyjarbók* and which preserves the Nórr variant of the *Frá Fornjóti* myth in its entirety, albeit in an edited and expanded form. To test this hypothesis, the article explores the relationship between these two texts and *Æ2–5* and interrogates the consensus that Magnús Þórhallsson was responsible for compiling *Æ1–5* and expanding *HNB*. The article concludes by pondering the reasons for the split between *HNB* and *Æ1* in *Flateyjarbók*.

1.1. *The form and function of HNB and Æ1–5 in Flateyjarbók*

Flateyjarbók was commissioned by the wealthy Icelander Jón Hákonarson and compiled in two production phases in the closing decades of the fourteenth century. The first was carried out by a scribe named Jón Þórðarson up until his departure from the project in 1387. His contributions to the manuscript were *Eiríks saga víðförla*, *Óláfs saga Tryggvasonar in mesta*, and most of *Óláfs saga ins helga*. He supplemented the latter two texts with extensive additional material – including entire sagas – and was responsible for incorporating *FN* into *Óláfs saga Tryggvasonar* (Rowe 2000: 442; Guðvarður Már Gunnlaugsson 2018: 206). From 1388/89 the manuscript was completed by Magnús Þórhallsson. After completing *Óláfs saga ins helga* he appended *Sverris saga*, *Hákonar saga Hákonarsonar*, and a set of annals and added several prefatory texts prior to *Eiríks saga* (Rowe 2005: 11–12 and 335; Guðvarður Már Gunnlaugsson 2018: 206 and 209–10). *HNB* and *Æ1–5* were included among these prefatory texts. Magnús was also responsible for the initials and rubrics found throughout the entire manuscript (Rowe 2005: 12, 318–19, and 325).

The shared features of the *Frá Fornjóti* legend concern the fortunes of the descendants of a being from northern Fenno-Scandia named Fornjótr. Fornjótr's descendants Nórr and Górr set out to search for their sister Gói after she goes missing one winter. After travelling overland to the west, Nórr reunites with his brother, who has travelled by sea. They divide the lands they have subdued between them: Nórr gains the mainland, which is subsequently known as Nórvegr (ON *Noregr* 'Norway'), whereas Górr takes control of the coastal islands. Gói is subsequently found in the Norwegian interior, having been abducted by a half-giant named Hrólfr í Bergi. At this point the accounts deviate. *FN* swiftly recounts the descent of Górr to a legendary figure named Hálfðan gamli 'the old' and thence to Jarl Rognvaldr of Mœrr 'Møre', from whom the

jarls of Orkney descend. *HNB* instead segues from a narrative account into a sparsely embellished descending genealogy of both Nórr and Górr's descendants. Nórr's sons and grandsons give their names to different petty kingdoms which correspond to Norway's medieval fylki 'regions, legal districts', and which their descendants rule as fylkiskonungar 'regional kings' prior to the regions' unification under Haraldr hárfagri (see ill. 1). This genealogy, comprising 116 dynasts to *FN*'s seventeen, ends abruptly with a great-grandson of Nórr named Eysteinn illræði 'ill-ruler'. Eysteinn is listed among the descendants of Nórr's son Raumr, the ostensible eponym for the kingdoms of Raumaríki 'Romerike' and Raumsdalr 'Romsdal'.

Æ1–5 relate the illustrious ancestry of Haraldr hárfagri, furnishing him with prestigious, pan-Scandinavian progenitors. As with *HNB*, these genealogies are descending, proceeding forwards in time from Haraldr's ancestors. *Æ2–5* all clearly derive from genealogical traditions known to have circulated in Iceland in the thirteenth and fourteenth centuries (see Faulkes 1977; 1978–79). Conversely, although *Æ1* is strewn with names drawn from across the corpus of Old Icelandic literature, the text as a whole has no parallel.

- *Æ1* is introduced as the “Ættartala fra Haud” (*Ættartölur*: 24) [the genealogy of Höðr], an eponym for Haðaland 'Hadeland'. It then lists the descent of Haddingr and Hringr – eponyms for Haddingjadalr 'Hallingdal' and Hringaríki 'Ringerike' respectively – who are listed among the sons of Raumr in *HNB*. Hringr's son Hálfðan gamli 'the old' is the progenitor of nine royal dynasties, most of which converge by matrilineal connections upon Haraldr hárfagri (see ill. 1). These matrilineal connections form part of a conceit introduced with Hálfðan gamli, to whom the gods granted that “þat mundi vera .ccc. vetra at eingi mundi vera vtiginn madr i hans ætt ok engi kona” (*Ættartölur*: 24) [for three hundred years there would not be any dishonourable man among his descendants and no woman]. Hálfðan's offspring are therefore traced to his first direct female descendants who provide matrilineal links to Haraldr hárfagri's ancestry.
- *Æ2* (ill. 3) relates Haraldr's descent from various ancestors of the legendary hero Ragnarr loðbrók 'shaggy breeches', who by the thirteenth century was regarded as a pan-Scandinavian progenitor in his own right

(Rowe 2009: 347 and 356; 2012: 181–223; Clunies Ross 1993: 381; Turville-Petre 1978–81: 22–23).³

- *Æ3*, following the established twelfth- and thirteenth-century royal narrative originally derived from the Viking Age poem *Ynglingatal* (Faulkes 1978–79: 96–97), connects Haraldr patrilineally to legendary rulers of Uppsala in Sweden and ultimately to their progenitor Yngvi, son of Óðinn. This dynasty is widely recognised as the Ynglingr dynasty in Old Norse literature but is not named in *Æ3*.
- *Æ4* links Haraldr matrilineally to the legendary progenitors of the Danish royal line traced back to Skjöldr Óðinsson. This was known as the Skjöldungr dynasty elsewhere, but again receives no name in *Æ4* (Clunies Ross 1993: 381; Faulkes 1978–79: 99).⁴
- *Æ5* follows European genealogical conventions by providing Haraldr with Classical and Christian origins.⁵ His ancestry is traced from Adam to Óðinn via Priam of Troy and thence to Haraldr through Skjöldr Óðinsson (albeit by a slightly different route than in *Æ4*).

HNB and each of *Æ1–5* are clearly demarcated in the manuscript by initials and/or rubrics. *HNB* begins with an elegant historiated initial “N”, its descender trailing two thirds the length of the text (*GKS 1005 fol.: 3v*). *Æ1* begins with an initial that is both smaller and far less elaborate, but it is nevertheless bigger than the initials that signal the start of *Æ3–5*, whereas *Æ2* does not have an initial at all, being signposted only by the accompanying rubric (*GKS 1005 fol.: 4r*). In her thorough analysis of the contents of *Flateyjarbók*, Elizabeth Ashman Rowe points out a largely consistent hierarchy in Magnús’s use of initials to demarcate new texts or sub-sections. According to her analysis, the size of the initial preceding *Æ1* places it firmly in the former category, suggesting that “Magnús considered at least the first chapter of [*Ættartölur*] as a separate text” which formed a “single textual unit” with *Æ2–5* (Rowe 2005: 318–19).⁶

3. See, for example, the genealogical table preserved in AM 1 e ß II fol., an eighteenth-century transcription of a fourteenth-century manuscript (Faulkes 1977: 178; 2005).
4. *Æ1* offers an entirely different Skjöldungr genealogy, naming Skjöldr as the son of Skelfir (from whom the Skilfingar descend) and grandson of Hálfdan gamli (see ill. 1).
5. Such conventions were an established feature of medieval European origin narratives from as early as the fifth century (Reynolds 1983: 375–80).
6. Rowe acknowledges that Magnús’s hierarchy was not always entirely consistent, drawing attention to the initials demarcating *Hynduljóð* in particular (Rowe 2005: 319).

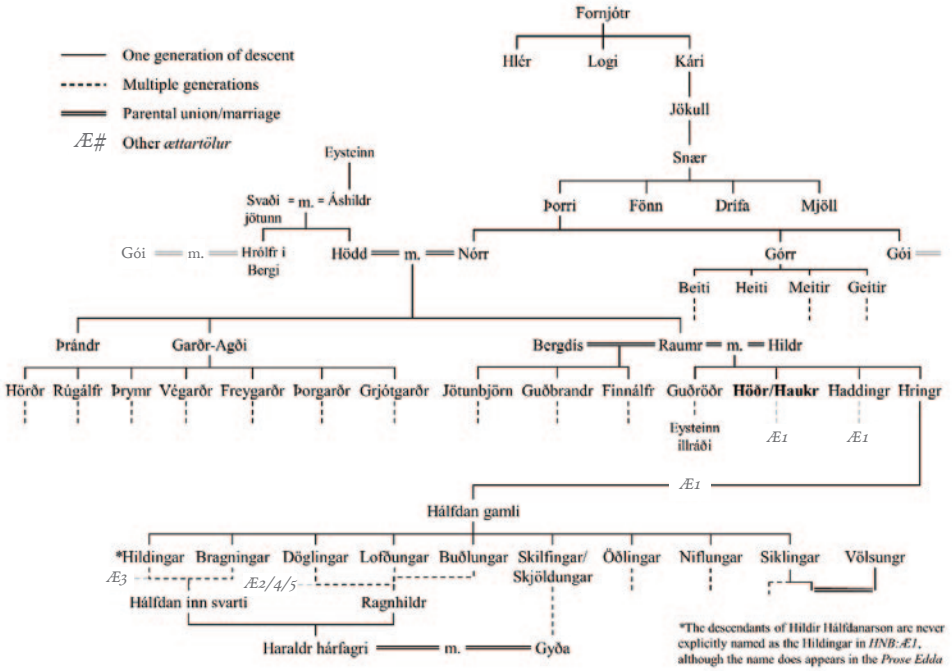

Ill. 1: Abridged graph of the descendants of Fornjótr in *HNB:Æ1*. The division between the two texts in *Flateyjarbók* is indicated by the bolding of Höör/Haukr.

It is no coincidence that both variants of the *Frá Fornjóti* myth show up in the same manuscript, nor that they were added in separate stages of its production; rather, their appearance reflects the varying principles that guided the compilation of *Flateyjarbók*. Rowe argues that Magnús Þórhallsson's additions during the second production phase, including *HNB* and *Æ1*–5, were motivated by a desire to update or respond to the themes introduced into the compilation by Jón Þórðarson (Rowe 2005: 27–28). *HNB* responds to information and themes found in both *FN* and *Eiríks saga víðförla*, which comes directly after Magnús's prefatory texts. It presents, as Rowe suggests, an alternative interpretation of kingship in Norway to the highly spiritual institution favoured by Jón and featured in *Eiríks saga*. On the level of the genealogies themselves, Magnús seems to have excised dynasties from *HNB* which were otherwise named in either *FN* or *Eiríks saga*. As Rowe notes, the descendants of Heiti Górrsson, who are listed in *FN*, are missing from the catalogue.

So too is the line of Þrándr Nórsson, the eponym for Þrándheimr ‘Trondheim/Trøndelag’; a Þrándr “er fyrstr red firir Þrandhæime” (*Saga Eireks Viðförla*: 29) [who first ruled over Þrándheimr] appears in *Eiríks saga* as the father of the protagonist. Conversely, the genealogies of Haraldr hárfagri expand Jón’s narrow focus on Norway and Iceland to incorporate both a Scandinavian context – conveyed by *ÆI*–4 – and a “universal” one expressed by the descent from Adam in *Æ5* (Rowe 2005: 331). This process of responding through his textual additions reveals Magnús’s prodigious skill as an editor but should not lead us to overstate the extent of his role in shaping the texts themselves.

2 Narrative and stylistic continuity

Despite their apparent demarcation as separate texts in *Flateyjarbók*, there are several indications of a narrative continuity between the two texts which demand further exploration. This is apparent from *HNB*’s opening sentence, which offers a synopsis encompassing the content of both texts:

Nu skal segia þemi til huersu Noregr bygdiz i fystu edr huersu konunga ættir hofuz þar edr i odrum londum. edr hui þeir heita Skioldungar Budlungar Bragningar Odlingar Valsungar edr Niflungar sem konunga ættirnar eru af komnar (*Huersu Noregr bygdiz*: 21)

Now we shall speak of how Norway was first settled, how the families of kings began there or in other lands and why they are called Skjöldungar, Buðlungar, Bragningar, Öðlingar, Völsungar and Niflungar, from whom the families of kings are derived.

The contents of *HNB* correspond solely to the first part of this synopsis: the settlement of Norway and the origin of the families of kings there. All but one of the royal families that are then listed are mentioned in *ÆI* as descendants of eponymous sons of Hálfðan gamli. The exception is the Völsungar, whose progenitor, Völsungr, nevertheless appears as the father-in-law of one of Hálfðan’s grandsons. That some of these families were based “i odrum londum” [in other lands] is indicated both within *ÆI* itself – which for example notes that the Buðlungar and Öðlingar

ruled Saxland ‘Saxony’ and Valland ‘Gaul’ – and in sources known to its compilers. The *Prose Edda*, for example, associates the Skjöldungr dynasty with Denmark and the Völsungar with Francia (*Edda: Prologue and Gylfaginning*: 5).⁷

It is unclear if this précis was found in earlier versions of *HNB* or was added by Magnús when he incorporated the texts into *Flateyjarbók*, as Rowe (2005: 330) suggests. If the latter was the case, it is curious that Magnús would choose to divide the texts so decisively having summarised them jointly in this way.

The grouping of the two texts in this précis is reflected in the dynasts they share, which draw a direct genealogical line from the foundation and settlement of Norway by Nórr and his offspring to the named “konunga ættir” [families of kings]. *HNB* concludes with the offspring of Nórr’s son Raumr, whose sons include Haddingr and Hringr. As noted, Haddingr and Hringr are listed along with their descendants in *ÆI*, establishing a direct line from Nórr to Hringr’s son Hálfðan gamli, the well-spring of the Skjöldungr, Buðlungr, Bragningr, Öðlingr, and Niflungr dynasties, among others, as well as the maternal ancestor of Haraldr hárfagri.

This sense of dynastic continuity is reflected on a stylistic level. This is most apparent in the preoccupation with eponymous figures which pervades both texts. Eponyms are found throughout *HNB* from Fornjótr’s sons Hlér, Logi, and Kári, whose names, denote the sea, flame, and wind (Clunies Ross 1983: 57–61), down to Nórr and his descendants, from whom Norwegian regions and locations are named. *ÆI* continues this trend with Höðr, Haddingr, and Hringr, with additional eponymous individuals scattered among their descendants.

Stylistic parallels run even more deeply than this, in the choice of language found in both texts. In *HNB*, the strength of the relationship between the descendants of Nórr and their kingdoms is repeatedly expressed with ON *v. eiga* ‘to own, to marry’ (3rd sg. pret. átti): “Rugalfri aatti Rogaland ... Freygarðr aatte Fiordu ok Fialer” [Rúgálfr owned Rogaland ... Freyjarðr owned Firðir ‘Fjordane’ and Fjalir ‘Fjaler’] (*Huersu*

7. In addition, Turville-Petre (1978–81: 14) points out that the classification of six of Hálfðan’s nine sons as so-called *sækonungar* ‘sea-kings’ and *herkonungar* ‘army-kings’ suggests that only the remaining three were necessarily intended to be based in Norway.

Noregr bygdiz: 23), and so forth. This pattern is repeated in *ÆI* with the sons of Raumr: “Haudr aatti þar ríki er kallað er Haðaland ... Hadding son Rauma aatti Haddingjadal ok Þelamörk” (*Ættartölur*: 24) [Höðr owned the kingdom which is called Haðaland ... Haddingr, son of Raumr, owned Haddingjadalr and Þelamörk ‘Telemark’], etc. *Eiga* is used in this sense fourteen times across *HNB* and *ÆI*, out of thirty total usages.⁸ Conversely, the more typical ON *v. ráða* ‘to rule’ is found on only four occasions.

The use of this verb to imply these rulers’ inherent ownership or even union with their kingdoms evokes the familiar medieval motif of rulers symbolically “marrying” the land (see, for example, Steinsland 2011: 30–32). It is integral to the legend’s creation of an inherent social hierarchy, binding the descendants of Nórr to the Norwegian regional landscape and reinforcing the legend’s more obvious etymological connections (Nórr – Norway; Rugálfr – Rogaland; Höðr – Haðaland).

2.1. *Haukr and Höðr*

Given these indications of narrative and stylistic continuity between *HNB* and *ÆI*, the boundary between the two texts is at first glance somewhat jarring. As noted, *HNB* concludes abruptly with Eysteinn illráði, who appears among the enumeration of the offspring of Raumr Nórsson. Eysteinn’s father Guðröðr is the first of Raumr’s four sons with Hildr Guðröðardóttir to be named in *HNB*, followed (in order) by Haukr, Haddingr, and Hringr. *ÆI* begins with the descendants of an apparently parentless individual named Höðr and was thus labelled “Ættartala fra Haud” by Magnús Þórhallsson in the rubric which accompanies the start of the chapter. Once Höðr’s descendants have been listed, however, *ÆI* returns to relate the offspring of Raumr’s last two sons, Haddingr and Hringr. These dynasties are thus related in the same order that their founders, the sons of Raumr and Hildr, are named in *HNB*, but with Höðr and his descendants occupying the position where we would expect to find the line of Haukr, which receives no mention.

8. Nine of the remainder relate to dynastic marriage and five to children: “Forníoti ... aatti .iij. sonu” [Fornjótr had three sons] (*Huersu Noregr bygdiz*: 21), “Dagr aatti Þoru drengiamodur” [Dagr married Þóra drengjamóður ‘mother of princes’] (*Ættartölur*: 25). Both usages are distributed across the boundary between *HNB* and *ÆI*.

By taking account of a scribal error, it becomes clear that the genealogies actually continue over the divide without interruption. The name of Raumr's fifth child has evidently been miscopied in *HNB* as "haukr", rather than "haudr", as Höðr is rendered in the orthography of the manuscript (*GKS 1005 fol.: 4r*). We can be certain that the error occurred in this direction as Höðr is clearly an eponym for his associated realm of Haðaland, which also follows the pattern of Hringr and Haddingr (see above); Haukr has no Norwegian regional analogue.⁹ With this error accounted for, the stylistic flow between the two texts is even more apparent. This impression of stylistic and thematic unity is strengthened even further when one looks beyond the texts themselves to the sources that informed them.

3 The common sources of *HNB* and *ÆI*

Unlike the genealogies found in each of *Æ2–5*, those in both *HNB* and *ÆI* are not copied from a single tradition, but rather cobbled together from a broad variety of sources from across the corpus of Old Icelandic literature (Allport 2022 [forthcoming]). The identification of these sources reveals strata of varying material which attest to successive stages of composition and expansion in both texts prior to their addition to *Flateyjarbók*. Dynasts found in both texts can be categorised by the certainty with which their sources can be identified. The sources which can be identified with the most confidence are those that contributed one or more sequences of names to the text. If a succession of several dynasts from the same family is found in either *HNB* or *ÆI* and in another text, then it is likely that these texts are interdependent. Given the hotchpotch nature of the genealogies in *HNB* and *ÆI*, we can assume that, in most instances, these names were borrowed into them, rather than being sourced from them.

9. Guðröðr, the eldest son of Raumr and Hildir, is also not an eponym, but this is justified within the conceit of the origin legend, as he inherits his father's kingdom of Raumaríki, which has already been named for its first ruler. The same pattern can be observed with Þrymr, the son of Garðr-Agði, who inherits his kingdom of Agðir 'Agder', and Jötunbjörn, Raumr's son by the giantess Bergdis, who inherits Raumsdalr.

This analysis reveals that both texts drew upon the same four or more key sources for upwards of eighty dynasts. The four sources which can be identified with the most certainty for both texts are the Eddic poem *Hyndluljóð*; Snorri Sturluson’s *Prose Edda*; the *Nafnaþulur* ‘Lists of Names’ which accompany several manuscripts of the latter (*Edda: Skáldskaparmál*: vol. 1, xv–xviii and 109–10); and the legendary saga *Hálfs saga ok Hálfsrekka* (Allport 2022 [forthcoming]). Each of these texts contributed names to both *HNB* and *ÆI* (see ill. 2).

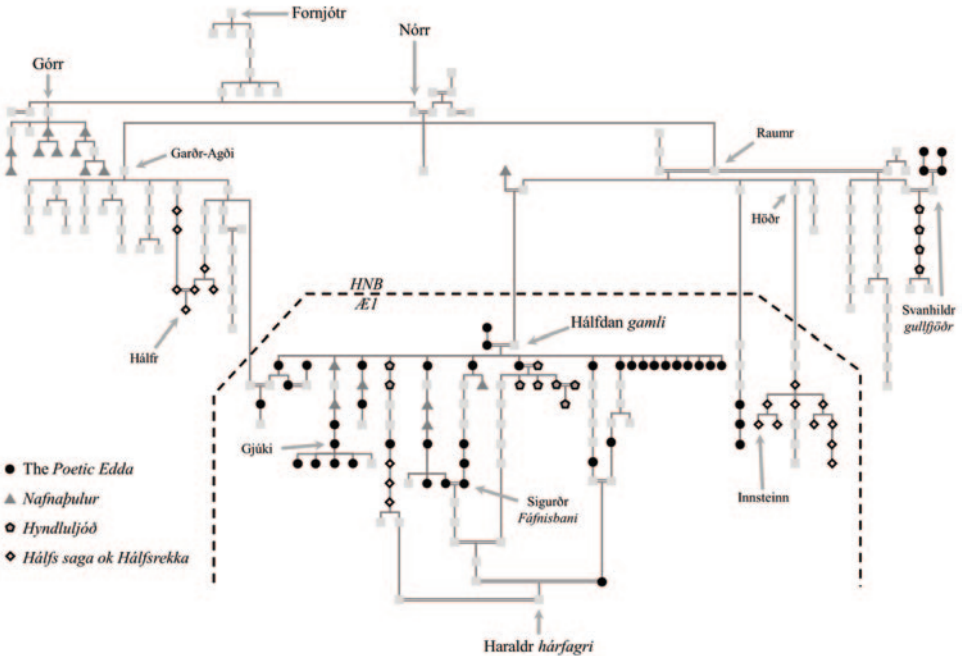

Ill. 2: A visualisation of the descendants of Fornjótr in *HNB* and *ÆI* showing dynasts obtained from the same sources on both sides of the textual divide. Dynasts significant to the following discussion are labelled.

The most extensive borrowing in *ÆI* is from the *Prose Edda*, which contributed an entire passage describing the life of Hálfdan gamli and inspired the structure of this section of the genealogies. The corresponding passage in the *Prose Edda* lists Hálfdan’s eighteen sons and, for each of the last nine, notes a couple of prominent descendants. In *ÆI*, these references were extended into complete and detailed genealogies. Many of

these new dynasts were drawn from elsewhere in the *Prose Edda*, often building on the fleeting references to prominent descendants already present in the passage. Thus, the references to the legendary figures Sigurðr Fáfnisbani, Brynhildr Buðladóttir, and Gjúki, all of whom feature prominently in the *Edda*'s borrowings from the *Völsunga saga* narrative, are supplemented with the family members that appear amidst those borrowings, such as Gjúki's offspring Gunnarr, Högni, Guðrún, and Guðný (*Edda: Skáldskaparmál*: vol. 1, 47). The *Edda* was clearly also the source for Dagr Dellingsson and Sól Mundilfaradóttir, who appear in *HNB* as the in-laws of Raumr Nórsson (*Edda: Prologue and Gylfaginning*: 13). *HNB* gives them a daughter, Svanhildr gullfjöðr 'Gold-feather', who is married to Raumr's son Álfr, also referred to as Finnálfr inn gamli 'the old'.¹⁰

Several of the names of Hálfðan's descendants are drawn from a list of *sækonungar* 'sea-kings' found in the *Nafnapulur* that are attached to several manuscripts of the *Prose Edda* – including, we must assume, the one used by the compilers of both *HNB* and *ÆI*. These are distributed among the sons of Hálfðan who are identified as *sækonungar* in *ÆI* – Auði, Buðli, and Næfill – the latter two of whom also appear on the list.¹¹ A significant cluster of names from the list is also found prior to the divide among the offspring of Górr. Here, however, the situation is complicated by the fact that some of the names on the *sækonungar* list are also found in *FN*, including Górr himself. Górr's name presupposes the existence of its eponymous doublet Nórr, which is indeed attested far earlier.¹² Its appearance on the *sækonungar* list must therefore be based upon the *Frá Fornjóti* myth and not the reverse. Nevertheless, it is likely that Górr's dynasty was padded with additional names from the list during the expansion phase (perhaps noticing the existing correlation with names in *FN*).

10. See also "Family disunion", below.

11. See ill. 1, in which these individuals are represented by the dynasties they generate: the Öðlingar, Buðlungar, and Niflungar.

12. The name Nórr/Nori appears in two texts from the twelfth and/or early thirteenth centuries – the Danish *Chronicon Lethrense* and the *Óláfs saga Tryggvasonar* composed by the Icelander Oddr munkr 'the monk' Snorrason – and almost certainly appeared in the *Historia Norwegie*, a Latin text from twelfth-century Norway (*The Lejre Chronicle*: 314–15; *Historia Norwegie*: 15, 21–23, and 52–53; *Óláfs saga Tryggvasonar*: 72).

Hyndluljóð, which also refers to Hálfðan gamli, was used by a compiler of *ÆI* to supplement Hálfðan's family with additional dynasts, including Þóra drengjamóður 'mother of heroes', the wife of Hálfðan's son Dagr, and several of their descendants (*Hyndlolióð*: 291). Yet the largest direct borrowing from the poem is found in *HNB*. The son of the aforementioned dynasts Finnálfr and Svanhildr gullfjöðr is identified in *HNB* as Svanr inn rauði 'the red' and his direct descendants listed as Sæfari, father of Úlfr, father of Álfr.¹³ The corresponding verse in *Hyndluljóð* proceeds as follows:

Dú ert, Óttarr, borinn Innsteini,
 en Innsteinn var Álfi inom gamla,
 Álfr var Úlfi, Úlfr Sæfara,
 enn Sæfari Svan inom rauða.
 (*Hyndlolióð*: 290)

You, Óttarr, were born of Innsteinn, and Innsteinn was born of Álfr inn gamli, Álfr of Úlfr, Úlfr of Sæfari, and Sæfari of Svanr inn rauði.

Innsteinn also appears in *ÆI* as a descendant of Höðr through his mother Gunnlöð, in a significant borrowing from *Hálfs saga ok Hálfsrekka*.¹⁴

Hálfs saga relates the exploits (and grisly fate) of a legendary Norwegian hero named Hálfr and his band of companions. Many of the latter are found in *ÆI* among the descendants of Höðr – they include Innsteinn, his brother Útsteinn, and their cousins Hrókr inn hvíti 'the white' and Hrókr inn svartí 'the black' (see *Ættartölur*: 24; *Hálfs saga ok Hálfsrekka*: 107). Conversely, Hálfr himself appears in *HNB* along with maternal and paternal ancestry adapted from the saga; he is descended by two separate routes from Garðr-Agði, another son of Nórr.

13. This Álfr inn gamli, attested in *Hyndluljóð* and *Hálfs saga*, is the second of three individuals with this name and epithet in *HNB* and *ÆI*–5. He is not to be confused with Finnálfr inn gamli, his ancestor in *HNB*, or with the Álfr inn gamli who appears at the start of *Æ2* and is derived from the **Skjöldunga saga* tradition: see "Family disunion", below.
14. Although Innsteinn is not presented as Álfr's son in *HNB*:*ÆI*, this and Álfr's union with Gunnlöð is clarified in *Hálfs saga* (106), which itself undoubtedly drew the information from *Hyndluljóð*.

The borrowings from these four sources congregate in the most recent descendants of Nórr in both texts, from around the fourth generation after the eponymous founder figure. Furthermore, some of these sources, most notably the fourteenth-century *Hálfs saga* (Seelow 1993: 262), date from well after the earliest attestation of the *Frá Fornjóti* myth in *FN* in the 1220s. This implies that the names gleaned from these sources were added during at least one phase of expansion which occurred simultaneously in *HNB* and *ÆI*.

4 *HNB:ÆI* as a narrative unity prior to *Flateyjarbók*

This evidence for genealogical, stylistic, and thematic continuity between *HNB* and *ÆI* on the one hand and their shared use of the same key sources on the other proves beyond any reasonable doubt that the *HNB* and *ÆI* should be regarded as a narrative unity, despite their presentation as separate texts in *Flateyjarbók*. This is emphasised by the direct use of *Hálfs saga* as a source. Although the hero and his legend seem, from perfunctory references throughout the Old Norse corpus, to have been well-known, they did not have a strong literary tradition attached to them prior to the fourteenth century. Even then, this saga did not enjoy the wide circulation of texts such as the *Prose Edda* (Seelow 1993: 262).

There are two explanations for the unity of the texts as we have them. If, following consensus, Magnús is considered responsible for the compilation of the *Flateyjarbók Ættartölur*, we must conclude that he intricately crafted his first chapter of genealogies to act as a genealogical, thematic, and stylistic continuation of the pre-existing Nórr variant of the *Frá Fornjóti* myth. This interpretation requires that Magnús also undertook a significant expansion of the Nórr variant using the same sources from which he had compiled *ÆI*, producing *HNB* as it survives.

If we are to accept this interpretation, we must give Magnús a significant amount of credit for the skill with which he married *ÆI* and *HNB* stylistically, presenting the former as the culmination of the themes of the latter. However, Magnús's decision to split this narrative unity and his error in writing "haukr" for "haudr" sit uneasily with this explanation, as both indicate a less intimate awareness of the genealogical continuity between *HNB* and *ÆI* than we would expect if Magnús had shaped both texts so integrally. This encourages us to entertain a second possibility:

that *HNB* and *ÆI* existed together in some form prior to their codification as separate texts by Magnús in *Flateyjarbók*, jointly representing a previous version of the Nórr variant of the *Frá Fornjóti* myth.

An initial case for this explanation can be built on two further observations about the overall narrative unity of *HNB:ÆI* that suggest that the core narrative of *HNB* could not, on its own, have represented the version of the Nórr variant known to Magnús, but must already have included the broad narrative elements contributed by *ÆI*.

The first, and most speculative, of these, is that the abrupt end of *HNB* as it stands in the manuscript seems to bring the origin legend to a curiously negative, even subversive finale, which makes it unlikely to be the original end of the legend as Magnús received it. The text ends with Eysteinn illráði, whose father Guðröðr inherited the kingdom of Raumaríki from Raumr Nórrsson. It is noted that Eysteinn installed a dog named Saurr to rule over the Innþrændir ‘residents of inner Trøndelag’ “fyrir þat er þeir hofdu drepit Aunund, son hans” (*Huersu Noregr bygdiz*: 24) [because they had killed Öundur, his son].¹⁵ This, combined with Eysteinn’s undesirable epithet (‘ill-ruler’), jars with the function of the legend, which, as Rowe (2000: 446; 2005: 322) suggests, was to explore both the naming of the Norwegian regional landscape from Nórr’s offspring and the development of its social hierarchy. This aim must have existed to some extent in previous versions of the Nórr variant, as the dynasts it contributed to *Þorsteins saga Víkingssonar* (1–2) in the late thirteenth century included the regional eponyms Raumr, Hringr, and Álfr inn gamli. Rowe argues convincingly that one aim of the legend is to establish the immutability of the king and various other ranks of Norwegian nobility by the association of name and title, such that those dynasts or dynasties who have accepted the lower titles of jarl and hersir are no longer entitled to take up the rank of king. Yet *HNB* as we find it concludes with the satirical tale of a dog being elevated to royal status – without the acceptance of those it “ruled” – by a king whose nickname preserves for posterity his unsuitability for the role and the death of whose son ends Nórr’s line of succession on a sour note.

Accepting that the function of medieval origin legends was, as Susan Reynolds (1983: 380) put it, “to explain the present and to promote

15. The same story is found in *Hákonar saga góða* (164) and *Óláfs saga helga* (241) in the *Heimskringla* compilation and in *Af Upplendinga konungum* (145–46).

its values”, we may wonder which values were promoted by this ostensible ending, although we must also acknowledge that the motivations of medieval redactors are not always transparent. It is also conceivable that Magnús added the story to *HNB* simply to preserve it, prioritising the transmission of ancient lore over the political implications of its exact placement within the narrative.

Nevertheless, the addition of *ÆI* resolves the narrative that begins with Nórr’s creation of Norway in a manner more consistent with our expectations of origin legends. Eysteinn, Önuendr, and Saurr are now simply part of a catalogue of allusions to various legendary Norwegian heroes and rulers – such as Hálftr *berserkr* and Hrómundr Gripsson – buried within a web of genealogy. The denouement of the legend becomes the culmination of Nórr’s lines of descent in the figure of Haraldr hárfagri, the first of his progeny who would rule the entirety of the realm Nórr had created. This association of the realm’s creator with its ruling dynasty conforms to deeply entrenched origin legend motifs attested throughout the medieval period; as Faulkes (1978–9: 95) observes of the genre: “it is often unclear whether we are being told of the origin of a dynasty or of a nation”.¹⁶ By the legend’s conclusion with Haraldr, the social hierarchy of the Norwegian realm is established, and the ranks of its nobility have accepted their respective roles.

The necessity of *ÆI* as a conclusion to the narrative established in *HNB* is indicated more firmly by the second observation, based on a comparison of their combined narrative structure with *FN*. *FN* can be divided into four broad structural components:

- Fornjótr’s descent to Nórr, Górr, and Góí through his son Kári;
- The abduction and discovery of Góí and the creation of Norway;
- The division of Norway between Nórr’s offspring and Górr’s descent to Hálfðan gamli;
- The descent from Hálfðan to the “historical” subject of the legend, Jarl Røgnvaldr of Mœrr.

16. Prominent examples from the twelfth century include Geoffrey of Monmouth’s *Historia regum Britanniae* ‘History of the Kings of Britain’ and Saxo Grammaticus’s *Gesta Danorum* ‘Deeds of the Danes’.

HNB on its own corresponds only to the first two of these components and a part of the third, down to the division of Norway. However, with *ÆI* appended to *HNB* the correspondence between the two narratives is much closer, only differing in narrative terms in their primary historical subject and the founder from which they descend (respectively Haraldr hárfagri and Nórr in *HNB:ÆI*).

This correspondence is not perfect. The third and fourth components in *FN* are related brusquely, whereas in *HNB:ÆI* they occupy the greater part of the narrative. In all, six generations of Górr's descendants are described, in *HNB:ÆI* the tally of Nórr's descendants extends to the sixteenth generation. This is an indication of the expansion the myth underwent during at least 160 years of transmission, from the addition of *FN* to *Orkneyinga saga* by the 1220s up to the Nórr variant's insertion into *Flateyjarbók* in or after 1388.

The key to the correlation is the figure of Hálfðan gamli. As Preben Meulengracht Sørensen (1993: 216) noted; in *FN*, Hálfðan acts as a legendary intermediary between the historical subject of the myth and his founder forbears. The figure appears in only four other surviving medieval texts: a derivative passage in *Landnámabók*, the *Prose Edda* (*Edda: Skáldskaparmál*: vol. 1, 101 and 103), *Hyndluljóð* (*Hyndlolióð*: 290), and *ÆI*. The passage describing Hálfðan's life and offspring in *ÆI* is copied almost verbatim from the *Prose Edda*. Nevertheless, when *ÆI* and *HNB* are combined, he serves exactly the same intermediary purpose as in *FN*. He is even descended from the founder brothers (although from Nórr, not Górr) by the same number of generations. This suggests that he was present in an earlier version of the Nórr variant and played a similar structural role. At some point, his presence presumably inspired the incorporation of the Hálfðan narrative from the *Prose Edda* (Allport 2022 [forthcoming]).

This similarity in narrative structure between *FN* and *HNB:ÆI* supports the suggestion that the latter two texts have history as a single unit prior to their appearance in *Flateyjarbók*; however, the clarity of this image is obscured by signs that both texts have undergone a considerable process of expansion, whether at Magnús's hands or those of an earlier redactor. To further establish the probability of the texts' shared history, we must therefore turn to a comparison with their neighbours in *Flateyjarbók*, *Æ2–5*. Do these texts belong to the same narrative unity and

share the same sources, stylistic features, and themes? Do they show signs of being the work of the same or a different compiler?

5 Family disunion: the divide between *HNB:Æ1* and *Æ2–5*

It must first be noted that the narrative continuity which is so striking between *HNB* and *Æ1* is strikingly *absent* between *Æ1* and *Æ2–5*, despite the hierarchy of initials (or the lack of one in the case of *Æ2*), which indicates that Magnús regarded *Æ1–5* as a single text. The correspondence with *FN* ends with the conclusion of *Æ1* in the person of Haraldr hárfagri. The remaining *Ættartölur* converge upon Haraldr from diverse progenitors, so it cannot be argued that they continue the goal of the origin legend to extend the line of Fornjótr and Nórr down to even more recent descendants. Furthermore, *Æ1* ends with a distinct conclusion which wraps up the conceit exploring the female descendants of Hálfðan gamli and creates a clear narrative break with what follows.

The summative passage which so clearly outlines the content of both *HNB* and *Æ1* does not necessarily apply to the remaining chapters, which we might expect if, as Sigurður Nordal believed, *HNB* was added to preface the genealogies (see Rowe 2005: 317–18 and 330). The reference to “huersu konunga ættir hofuz þar edr i odrum londum” [how the families of kings began there or in other lands] (*Huersu Noregr bygdiz*: 21) is sufficiently vague that it might apply to *Æ2–5*, particularly given that those chapters locate Haraldr’s ancestors in Sweden, Denmark, Troy and even the Garden of Eden. Yet the summary goes on to say “edr hui þeir heita Skioldungar Budlungar Bragningar Odlingar Vaulsungar edr Niflungar” [and why they are called Skjöldungar, Buðlungar, Bragningar, Öðlingar, Völsungar and Niflungar] (*Huersu Noregr bygdiz*: 21) and none of these dynasty names are defined or even appear in *Æ2–5*. Although our awareness of broader tradition informs us that the descendants of Óðinn’s son Skjöldr, who feature in both *Æ4* and *Æ5*, were referred to as the Skjöldungar, *Æ1* provides a different derivation of the name, from a Skjöldr descended of Hálfðan gamli. Most tellingly, this summary makes no reference to the Ynglingar, Haraldr hárfagri’s own dynasty. The members of this dynasty are related in *Æ3*, although again the term ‘Ynglingar’ itself is not used here – or indeed anywhere in *HNB*, *Æ1*, or *Æ2–5*. Finally, the summary makes no reference to Haraldr’s more exotic

ancestry, such as Priam of Troy or Adam. These points may amount to an argument from absence, but they illustrate the fact that the same arguments used to link *HNB* and *Æ1* cannot be so persuasively applied to *Æ2–5*.

Æ2–5 utilise genealogical traditions in significantly different ways to *HNB* and *Æ1*. This is most evident on a stylistic level. Neither *HNB* nor *Æ1* are straightforward genealogies, in the purest sense of a list of dynasts and their relationships. They are structured around two main narratives – the story of Nórr, Górr, and Góí and that of Hálfðan and his female descendants – and contain frequent embellishments, noting connections to regions and alluding to their dynasts’ involvement in other legends. Conversely, *Æ2–5* have far fewer embellishments and are otherwise simple lists of names and relationships. Deviations are primarily restricted to one introductory and one concluding remark, such as “Burri hefir konungr heitid er reed fyrir Tyrklandi” (*Ættartölur*: 26) [there was a king called Burri who ruled over the land of the Turks] and “verdr þessi tala einum manni faatt i siau tughu at medtauldum bædi Adam ok Haralldi” (*Ættartölur*: 27) [this tally was one man fewer than seventy including both Adam and Haraldr]. The only apparently legendary allusion in these genealogies is found in *Æ3* and refers cryptically to “Aun. er .ix. vetr drack horn fyrir elli sakir aadr hann do” (*Ættartölur*: 26) [Aun, who drank the horn for nine winters for the sake of old age before he died].

The embellishments of *HNB* and *Æ1* reflect the high level of creativity involved in their expansion, combining snippets of information from a wide variety of poetic and narrative sources. *Æ2–5* are far more restricted in their source material and have little crossover with *Æ1* before they inevitably merge in the generations prior to Haraldr. *Æ3–5*, in particular, copied their dynasts without embellishment from established Icelandic genealogical tradition; they have been altered only when necessary to conform to the account of Haraldr’s immediate ancestry in the preceding chapters (see ill. 3).¹⁷ As Anthony Faulkes notes (1978–79: 104), *Æ4* and *Æ5* drew upon Icelandic langfeðgatal ‘ancestral lists’ – which incorporated information from the *Prose Edda*, the tradition derived from the lost **Skjöldunga saga*, and the genealogies attested in AM 1 e ß II fol. – to trace the descent of Adam to Óðinn and thence to Haraldr hárfagri through Óðinn’s son Skjöldr. *Æ3* is a straightforward copy of the Yng-

17. *Æ5*, for example, is identical to *Æ2* from the dynast Hróarr onwards.

lingr genealogy derived from the poem *Ynglingatal*. This genealogy began to circulate independently of its poetic context as early as the 1130s, when it was included as an appendix to Ari fróði Þorgilsson's *Íslendingabók* (*Íslendingabók*: 27–28; Faulkes 1978–79: 96–97).

Æ2 (referred to simply as “Ættartala” by the accompanying rubric) borrowed directly from a single tradition derived from **Skjöldunga saga* and has only six dynasts which are not shared with any of Æ1–5, but also shows signs of having been tailored to place emphasis on dynasts and connections that to some extent continue the themes of *HNB:Æ1* (see ill. 3).¹⁸ There is a focus on matrilineal connections even prior to the dynasts shared with Æ1, with Auðr in djúpauðga ‘the Deep-Minded’, Hervörreið Heiðreksdóttir, and Álfhildr Gandálfsdóttir offering important links to legendary progenitors. The genealogy is also scattered with legendary heroes, such as Ragnar loðbrók and Haraldr hilditǫnn ‘Battle-Tooth’, echoing those found in the lower echelons of both *HNB* and Æ1. There is even a link to an eponymous regional ruler; the genealogy begins with “Alfr konungr hinn gamli” (*Ættartölur*: 26) [King Álf the old], who “reed fyrir Aalfheimum” (*Ættartölur*: 26) [ruled over Álfheimr].

Nevertheless, these similarities are too imperfect to indicate they are part of the same project; they appear derivative, suggesting that *HNB:Æ1* was simply their inspiration, rather than the work of the same person. A hint of this can be seen in the previous quotation, with the abandonment of the formula expressing dynasts’ union with their realm. ON v. eiga ‘to own/to marry’ is substituted with ON v. ráða ‘to rule’ and is otherwise lacking from Æ2–5 beyond four references to dynastic marriage.

In addition, Álf’s rule of Álfheimr is the only instance in which an etymological link is implied between a ruler and a territory after Æ1. However, the name of the territory in question was already defined in *HNB*: it is named for its ruler Álfur Raumsson, also known as Finnálfr inn gamli. As these texts reveal (and somewhat to the detriment of the reader’s

18. There is some evidence that compilers of *HNB:Æ1* also drew upon a text derived from the **Skjöldunga saga* tradition as a source for a small number of dynasts, most notably Helgi hvassi ‘the sharp’ and his forebears Óláfr and Hringr, who are found among the offspring of Dagr, a son of Hálfðan gamli (*Þáttur af Ragnars sonum* 1950: 301). The source text in this instance was *Ragnarssona þáttur*, a synopsis found in the manuscript compilation *Hauksbók*, to which the compilers had access. *Ragnarssona þáttur* cannot itself have been the source for Æ2 as it omits many of the names in this genealogy.

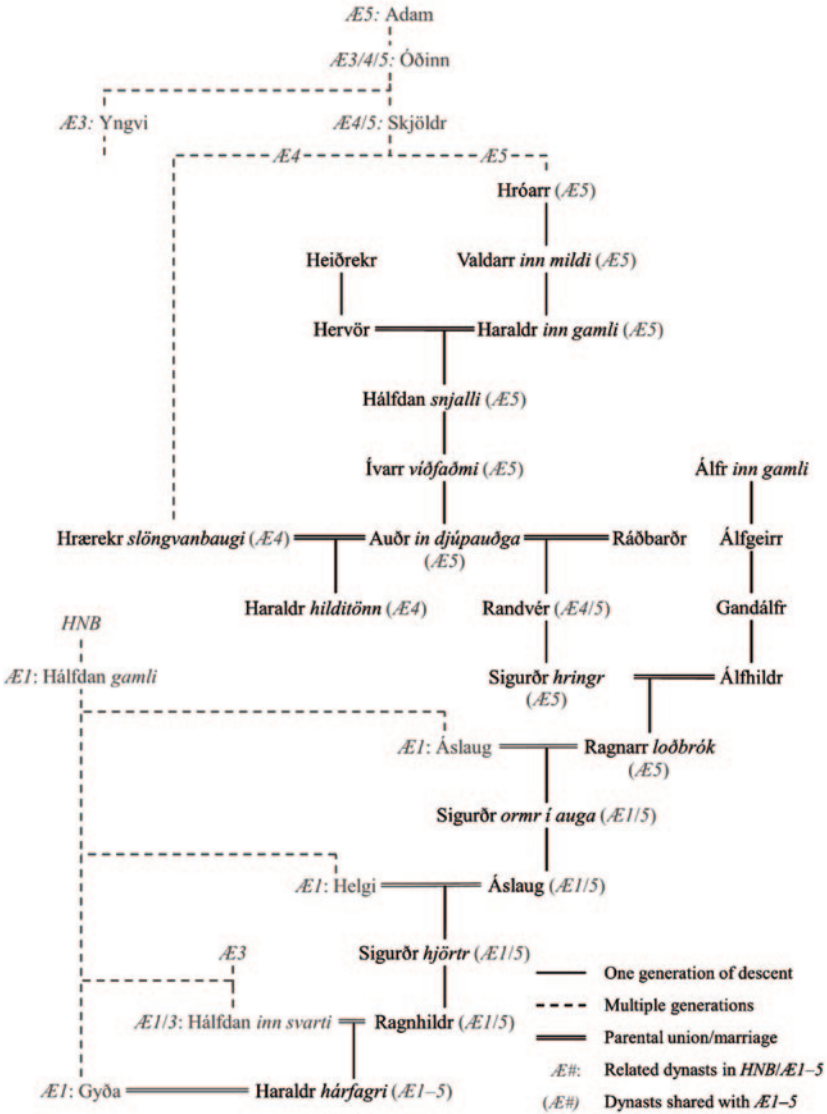

Ill. 3: Graph of Æ2 showing its relationship with the other texts under discussion.

comprehension), the name Álfr inn gamli was applied to a variety of figures throughout the Old Norse legendary corpus. No attempt is made in Æ2 to identify this genealogy's Álfr with the son of Raumr (for

example by appending the epithet Finn-), nor indeed with the individual who (as mentioned previously) was borrowed into Finnálfr's line from the poem *Hyndluljóð*. The choice to begin with Álfr inn gamli, a minor figure in the **Skjöldunga saga* tradition who appears in the maternal ancestry of Ragnarr loðbrók, suggests a relatively lacklustre attempt to conform to aspects of *HNB:Æ1*. It could be argued that this Álfr was intended to be regarded as yet another descendant of Finnálfr, who therefore does not "own" Álfheimr in the same way but simply rules it. Nothing in the text encourages this interpretation, but even if it did this does not indicate a more intimate relationship between *Æ2* and *HNB:Æ1* than mild intellectual engagement with the latter by the compiler of the former.¹⁹

Æ2 thus seems to mimic aspects of *HNB:Æ1* without the same consistency or unity of purpose and is more akin to *Æ3–5* in its loyalty to an existing tradition. As a whole, *Æ2–5* bear the hallmarks of being a subsequent project which shows an incomplete awareness of the thematic and stylistic principles of the preceding text. One logical implication of this is that the scribe Magnús Þórhallsson could not have been responsible for compiling both *HNB:Æ1* and *Æ2–5* in the form that we know them, although this cannot be demonstrated incontrovertibly.

The most likely scenario is that Magnús was responsible for compiling *Æ2–5*, in which case it is unlikely that he also compiled *HNB:Æ1*. The function of *Æ2–5* within *Flateyjarbók* gives every indication of Magnús's involvement. As Rowe observes, *HNB* and *Æ1–5* furnish Haraldr hárfagri with ancestry of an impressive geographical scope: *HNB:Æ1* and *Æ2* relate Norwegian heritage, *Æ3* Swedish, *Æ4* Danish, and *Æ5* Trojan and Christian (Rowe 2005: 331). This is consistent with Magnús's aim of expanding the more limited Norway- and Iceland-centric scope of his predecessor on the project, Jón Þórðarson, providing a motive for grouping this genealogical material in the way in which it is found (see Rowe 2005: 24, 27–28, and 330–31 for Jón's and Magnús's different approaches to historiography). In keeping with this aim of universal legitimisation, it makes sense that Magnús would simply reproduce well-established genealogical traditions which were espoused by the

19. A similarly moderate level of engagement is evident in the edits made to *HNB* identified in "form and function", above: the removal of the descendants of Heiti Górrsson and Þrándr Nórsson due to their appearance elsewhere in *Flateyjarbók*.

Norwegian and Danish royal families and by aristocratic Icelanders in their langfeðgatal. Conversely, compiling an entirely new, Norway-centric genealogical tradition (albeit based on the *Frá Fornjóti* myth) from bits and pieces of various different texts is less in keeping with this aim, particularly as this hotchpotch occasionally contradicts or otherwise conflicts with the established traditions.

Magnús clearly recognised the potential of *HNB:ÆI* to further his broader thematic goals. Although those goals are revealed by the addition of *Æ2–5*, this also allows us to recognise that *HNB:ÆI* as we know it does not wholly reflect Magnús's agenda. When combined with the previous arguments for *HNB:ÆI*'s fundamental narrative and thematic cohesion and the evidence of the shared sources which formed the basis for the myth's expansion, the likelihood that *HNB:ÆI* circulated in something close to its current form prior to its addition to *Flateyjarbók* becomes decidedly more pronounced.

6 Conclusion

The evidence of scribal errors, shared sources and structural parallels allows us to draw conclusions about the unity of *HNB:ÆI* with relative confidence. Furthermore, the absence of equivalent shared sources, themes, and style between *HNB:ÆI* and the genealogical chapters following it strongly suggests that the latter belonged to a separate, subsequent project.

However, the questions these conclusions pose force us to consider far more inscrutable circumstances. The most pressing question is, of course: why were *HNB* and *ÆI* divided? From our distant standpoint, it is difficult to understand the division, particularly given, for example, the thematic implications of ending with *Eysteinn illráði*. From a structural or thematic perspective, we might expect the divide to come before *Hálfðan gamli* as the most important intermediary between *Nórr* and *Haraldr hárfagri*, but also the point at which expanders of the tradition had incorporated vast swathes of new information and new themes, such as the focus on matrilineal connections. Magnús (if he was indeed responsible for the division and did not simply find it in his exemplar) may have wished to draw attention to *Eysteinn* or *Höðr*, for reasons which will remain obscure without having access to the scribe's thought pro-

cesses. Alternatively, the divide could have been inserted relatively arbitrarily to break up the narrative or for the sake of the *mise-en-page*. The most likely explanation may be that it was simply a mistake, perhaps occasioned by the accidental substitution of Höðr for Haukr, as the parentless Höðr therefore seemed to signal a departure from the descendants of Nórr listed prior to that point. Whatever the reason, the break is so incongruous to the structure of the narrative that it is unlikely that the same person was responsible both for splitting the texts and for compiling them in the form we know them.

Thus, by small steps, we begin to perceive the history of the tradition preserved in *HNB:Æ1*. The methodologies employed thus far have the potential to reveal far more about the Nórr variant of the *Frá Fornjóti* myth and demonstrate that it is at least as worthy of our attention as its sibling.

Bibliography

- Af Upplendinga konungum. Ed. Guðni Jónsson. *Fornaldar sögur norðurlanda*, vol. 2, 143–48. Reykjavík: Prentsmiðjan Edda h.f., 1950.
- Allport, Ben. 2022 [Forthcoming]. Genealogical Stratigraphy: Excavating an Expansion Phase in *Hversu Noregr byggðist* and the *Flateyjarbók Ættartölur*. *Viking and Medieval Scandinavia* 18.
- Beuermann, Ian. 2011. *Jarla Sogur Orkneyja*. Status and Power of the Earls of Orkney and Iceland c. 900–1300. *Ideology and Power in the Viking and Middle Ages*, ed. Gro Steinsland, Ian Beuermann, Jan Erik Rekdal & Jón Viðar Sigurðsson, 109–61. Turnhout: Brill.
- Clunies Ross, Margaret. 1983. Snorri Sturluson's Use of the Norse Origin-Legend of the Sons of Fornjótr in his *Edda*. *Arkiv för nordisk filologi* 98, 47–66.
- 1993. The Development of Old Norse Textual Worlds: Genealogical Structure as a Principle of Literary Organisation in Early Iceland. *Journal of English and Germanic Philology* 92, 372–85.
- Faulkes, Anthony. 1977. The Genealogies and Regnal Lists in a Manuscript in Resen's Library. In: *Sjöttu ritgerðir helgaðar Jakobi Benediktssyni 20. júlí 1977*, ed. Jakob Benediktsson, 177–90. Reykjavík: Stofnun Árna Magnússonar.
- 1978–9. Descent from the Gods. *Medieval Scandinavia* 11, 92–125.

- 2005. The Earliest Icelandic Genealogies and Regnal Lists. *Saga Book of the Viking Society for Northern Research* 29, 115–19.
- Finnbogi Guðmundsson. 1993. The Writing of *Orkneyinga saga*. In: *The Viking Age in Caithness, Orkney and the North Atlantic: Select Papers from the Proceedings of the Eleventh Viking Congress, Thurso and Kirkwall, 22 August–1 September 1989*, ed. Colleen E. Batey, Judith Jesch & Christopher D. Morris, 204–11. Edinburgh: University Press.
- GKS 1005 fol. Handrit.is, accessed November 14, 2020. <https://handrit.is/en/manuscript/imaging/is/GKS02-1005>.
- Guðvarður Már Gunnlaugsson. 2018. The Speed of the Scribes. How Fast could Flateyjarbók have been Written? In: *RE:writing: Medieval Perspectives on Textual Culture in the Icelandic Middle Ages*, ed. Kate Heslop & Jürg Glauser, 195–224. Zürich: Chronos Verlag.
- Hákonar saga góða. Ed. Bjarni Aðalbjarnarson. *Heimskringla*, vol. 1, 150–97. Reykjavík: Hið íslenska fornritafélag, 1941.
- Halfs saga ok Hálsrekka. Ed. Guðni Jónsson. *Fornaldar sögur norðurlanda*, vol. 2, 93–134. Reykjavík: Prentsmiðjan Edda h.f., 1950.
- Historia Norwegie*, ed. Inger Ekrem & Lars Boje Mortensen. 2003. Copenhagen: Museum Tusulanum Press.
- Huersu Noregr bygdiz. Ed. Guðbrandr Vigfússon & Carl Rikard Unger. *Flateyjarbók: En samling af norske konge-sagaer*, vol. 1, 21–24. Christiania: P. T. Mallings forlagsboghandel, 1860.
- Hversu Noregr byggðist. Ed. Guðni Jónsson. *Fornaldar sögur norðurlanda*, vol. 2, 75–87. Reykjavík: Prentsmiðjan Edda h.f., 1950.
- Hyndlolióð. Ed. G. Neckel & H. Kuhn. *Edda: die Lieder des Codex Regius nebst verwandten Denkmälern*, vol. 1, 288–96. Heidelberg: Carl Winter Universitätsverlag. 1962.
- Íslendingabók. Ed. Jakob Benediktsson. *Íslendingabók; Landnámabók*, 1–28. Reykjavík: Hið íslenska fornritafélag, 1986.
- The Lejre Chronicle (Chronicon Lethrense) Chapters 1–9. Ed. Carole E. Newlands. *Beowulf and Lejre*, ed. John D. Niles, 311–27. Tempe, Arizona: ACMRS, 2007.
- Meulengracht Sørensen, Preben. 1993. The Sea, the Flame and the Wind: The Legendary Ancestors of the Earls of Orkney. In: *The Viking Age in Caithness, Orkney and the North Atlantic: Select Papers from the Proceedings of the Eleventh Viking Congress, Thurso and Kirkwall, 22 August–1 September 1989*, ed. Colleen E. Batey, Judith Jesch & Christopher D. Morris, 212–21. Edinburgh: University Press.

- Óláfs saga helga. Ed. Bjarni Aðalbjarnarson. *Heimskringla*, vol. 2, 3–415. Reykjavík: Hið íslenska fornritafélag, 1945.
- Óláfs saga Tryggvasonar. Ed. Guðni Jónsson. *Konunga sögur*, vol. 1, 1–191. Akureyri: Prentverk Odds Björnssonar h.f., 1957.
- Orkneyinga saga*, ed. Finnbogi Guðmundsson. 1965. Reykjavík: Hið íslenska fornritafélag.
- Reynolds, Susan. 1983. Medieval *Origines Gentium* and the Community of the Realm. *History: The Journal of the Historical Association* 68, 375–90.
- Rowe, Elizabeth Ashman. 2000. Origin Legends and Foundation Myths in Flateyjarbók. In: *Old Norse Myths, Literature and Society: Proceedings of the 11th International Saga Conference, 2–7 July 2000, University of Sydney*, ed. Geraldine Barnes & Margaret Clunies Ross, 441–54. Sydney: Centre for Medieval Studies, University of Sydney.
- 2004. Absent Mothers and the Sons of Fornjótr: Late Thirteenth-Century Monarchist Ideology in *Þorsteins saga Víkingssonar*. *Mediaeval Scandinavia* 14, 133–60.
- 2005. *The Development of Flateyjarbók: Iceland and the Norwegian Dynastic Crisis of 1389*. Odense: University Press of Southern Denmark.
- 2009. *Ragnars saga loðbrókar, Ragnarssona þátr*, and the Political World of Haukr Erlendsson. In: *Fornaldarsagaerne: Myter og virkelighed: Studier i de oldislandske fornaldarsögur Norðurlanda*, ed. Agneta Ney, Ármann Jakobsson & Annette Lassen, 347–60. Copenhagen: Museum Tusulanum Press.
- 2012. *Vikings in the West: The Legend of Ragnarr Loðbrók and His Sons*. *Studia Mediaevalia Septentrionalia* 18. Vienna: Fassbaender.
- Saga Eireks Víðförla*. Ed. Guðbrandr Vigfússon & Carl Rikard Unger. *Flateyjarbok: En samling af norske konge-sagaer*, vol. 1, 29–36. Christiania: P. T. Mallings forlagsboghandel, 1860.
- Seelow, Hubert. 1993. Hálf saga ok Hálf srekka. *Medieval Scandinavia: An Encyclopedia*, ed. Phillip Pulsiano, 262. New York: Garland Publishing Inc.
- Snorri Sturluson, Edda: Prologue and Gylfaginning*, ed. Anthony Faulkes. 2005. London: Viking Society for Northern Research.
- Snorri Sturluson, Edda: Skáldskaparmál*, ed. Anthony Faulkes. 2 vols. 1998. London: Viking Society for Northern Research.
- Steinsland, Gro. 2011. Origin Myths and Rulership. From the Viking Age Ruler to the Ruler of Medieval Historiography: Continuity,

Transformations and Innovations. In: *Ideology and Power in the Viking and Middle Ages*, ed. Gro Steinsland, Ian Beuermann, Jan Erik Rekdal & Jón Viðar Sigurðsson, 13–67. Turnhout: Brill.

Turville-Petre, Joan. 1978–81. The Genealogist and History: Ari to Snorri. *Saga Book of the Viking Society for Northern Research* 20, 7–23. Ættartölur. Ed. Guðbrandr Vigfússon & Carl Rikard Unger. *Flateyjarbók: En samling af norske konge-sagaer*, vol. 1, 24–29. Christiania: P. T. Mallings forlagsboghandel, 1860.

Pátr af Ragnars sonum. Ed. Guðni Jónsson. *Fornaldar sögur norðurlanda*, vol. 1, 287–303. Reykjavík: Prentsmiðjan Edda h.f., 1950.

Þorsteins saga Víkingssonar. Ed. Guðni Jónsson. *Fornaldar sögur norðurlanda*, vol. 3, 1–73. Reykjavík: Prentsmiðjan Edda h.f., 1950.

Abstract

The origin legend referred to as *Frá Fornjóti ok hans ættmönnum* ‘Concerning Fornjótr and his Kinsmen’ is preserved in two variants in the fourteenth-century Icelandic compilation known as *Flateyjarbók*. It traces the origins of various prominent Norwegian and Orcadian dynasties to two brothers named Nórr and Górr. The variant considered to be younger of the two, referred to herein as the “Nórr Variant”, is represented by a text known as *Hversu Noregr byggðist* ‘How Norway was Settled’, which has a complicated textual relationship with five chapters of *Ættartölur* ‘Genealogies’ that follow it in the manuscript. Although related in content, the compiler of the manuscripts, Magnús Þórhallsson, who has often been attributed a role in compiling these texts, clearly demarcated them with initials. This article explores the relationship between *Hversu Noregr byggðist* and the first of these genealogical chapters. It is demonstrated that there is a continuity of narrative and style across the two texts and that both texts are indebted to the same literary traditions for the dynasts that swell the ranks of Nórr’s descendants. On this basis, it is hypothesised that the two texts should be regarded as a textual unity which was split when the manuscript was compiled. The narrative structure of the combined texts is comparable to that of the other variant of the myth, represented by the text *Fundinn Noregr* ‘Norway Founded’. It is argued that the same continuity seen between *Hversu Noregr byggðist*

A FAMILY REUNION

and the first chapter of *Ættartölur* is not shared with the remaining four chapters, and it is therefore suggested that Magnús Þórhallsson is unlikely to have been the author of the Nórr version as we know it.

Ben Allport
Universitetet i Bergen
Institutt for lingvistiske, litterære og estetiske studier
Postboks 7805
NO-5020 Bergen

The Old Smithy,
Great Bolas,
Shropshire
GB-TF6 6PQ

benallport793@gmail.com